



# LED Traffic Signal Module Extended View

**GREEN** Technology

**EV Series**

## The Leotek LED Advantage

Designed to direct more light above and below the typical horizontal axis requirement. "Fail-State Impedance" design to ensure controller and monitor compatibility in the event of loss of light output.

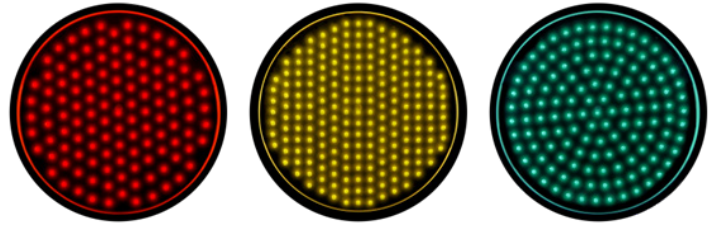

## Features and Benefits

- Environmentally friendly
- Significant energy and maintenance savings
- 8" and 12" modules
- Tinted or clear lens options
- Multiple connections available for specific applications
- Exceptional color uniformity and readability
- Excellent moisture and dust resistance through complete O-ring sealing
- Robust hard-coated and UV-stabilized polycarbonate lens for increased longevity against the elements
- Engineered aluminum heat sink for optimum thermal management
- Built-in Constant Current Source (CCS) provides uniform light output from the first to the last modules
- Maintains 70% of the initial lumen intensity after 50,000 hours of operation
- 5-Year Limited Warranty

## Technical Data

Operating Temperature: -40°F to 165°F (-40°C to 74°C)	Turn-On/Turn-Off Time: <75msec
Operating Voltage: 80 - 135Vac	Turn-Off Voltage: >35Vac
Power Factor: >0.90	Total Harmonic Distortion (THD): <20%



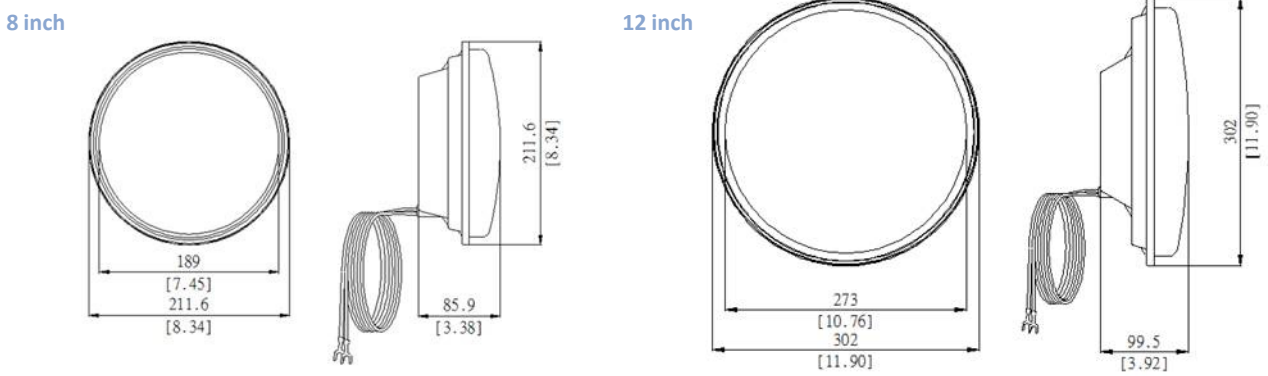









## Mechanical Dimensions [mm(in)]



# Model Specifications and Ordering Options

Example: TSL-EV12R-HPE-A1

**TSL-(SERIES)(SIZE)(COLOR)-(OUTPUT CHARACTERISTICS)-(VOLTAGE)**

Model Number and Color	Wattage Drawn	Voltage	Dominant Wavelength	Maintained Intensity (cd) Min.	Standard
<b>8 inch</b>					
TSL-EV08R-HPE-A1 	7	80-135Vac	626	165	ITE 2005
TSL-EV08Y-HPE-A1 	11	80-135Vac	589	410	ITE 2005
TSL-EV08G-HPE-A1 	10	80-135Vac	500	215	ITE 2005
TSL-EV08R-HP2-A1 	7	80-135Vac	626	133	ITE 1998
TSL-EV08Y-HP2-A1 	8	80-135Vac	589	267	ITE 1998
TSL-EV08G-HP2-A1 	8	80-135Vac	500	267	ITE 1998
<b>12 inch</b>					
TSL-EV12R-HPE-A1 	7	80-135Vac	626	365	ITE 2005
TSL-EV12Y-HPE-A1 	21	80-135Vac	589	910	ITE 2005
TSL-EV12G-HPE-A1 	8	80-135Vac	500	475	ITE 2005
TSL-EV12R-HP3-A1 	9	80-135Vac	626	399	ITE 1998
TSL-EV12Y-HP1-A1 	18	80-135Vac	589	678	ITE 1998
TSL-EV12Y-HP5-A1 	29	80-135Vac	589	678	ITE 1998
TSL-EV12G-HP3-A1 	11	80-135Vac	500	678	ITE 1998

**Options:** Tinted lens standard, clear lens optional.

## Standard Conformance



- FCC Compliant for Electrical Noise
- MIL-STD-810F Moisture Resistant
- MIL-STD-883 Mechanical Vibration
- NEMA TS2 Transient Voltage Protection over 2000V

### ITE VTCSH Compliance - LED Circular Signal Supplement – June 2005

- |                        |             |                       |               |
|------------------------|-------------|-----------------------|---------------|
| · Conditioning         | ITE 6.4.2   | · Luminous Intensity  | ITE 6.4.4.1-4 |
| · Mechanical Vibration | ITE 6.4.3.1 | · Chromaticity        | ITE 6.4.4.6   |
| · Temperature Cycling  | ITE 6.4.3.2 | · Current Consumption | ITE 6.4.6.1   |

**LEOTEK USA**  
 1330 Memorex Drive  
 Santa Clara, CA 95050  
 Toll Free: (888) 806-1188  
 Fax: (408) 980-0538

**LEOTEK TAIWAN**  
 No. 50 Lung-Yuan 7<sup>th</sup> Road  
 Lung-Tan, Tao-Yuan Hsien 325  
 Taiwan  
 Telephone: 886-3-4995939  
 Fax: 886-3-4995930

[www.leotek.com](http://www.leotek.com)  
[www.liteon.com](http://www.liteon.com)

