



LED Pedestrian Signal Module Type 2 Screw-In Base Design



The Leotek LED Advantage

Compact Edison-base, screw-in design with "Fail-State Impedance" to ensure controller and monitor compatibility in the event of loss of light output. No modification to pedestrian housing required.

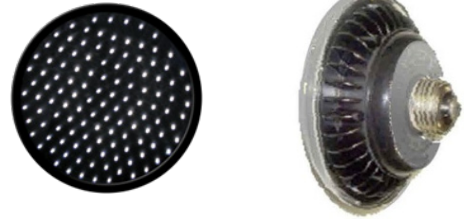

Features and Benefits

- Environmentally friendly
- Significant energy and maintenance savings
- 9" and 12" modules
- Simple and fast installation
- Exceptional color uniformity and readability
- Maintains 70% of the initial lumen intensity after 50,000 hours of operation
- Excellent moisture and dust resistance through complete O-ring sealing
- Robust hard-coated and UV-stabilized polycarbonate lens for increased longevity against the elements
- Built-in Constant Current Source (CCS) provides uniform light output from the first to the last modules
- 5-Year Limited Warranty

Technical Data

LED Color/Type:	Portland Orange/AlInGaP, Lunar White/InGaN		
Operating Temperature:	-40°F to 165°F (-40°C to 74°C)	Total Harmonic Distortion (THD):	<20%
Operating Voltage:	80 - 135Vac	Turn-On/Turn-Off Time:	<75msec
Power Factor:	>0.90	Turn-Off Voltage:	>35Vac

Mechanical Dimensions [mm(in)]



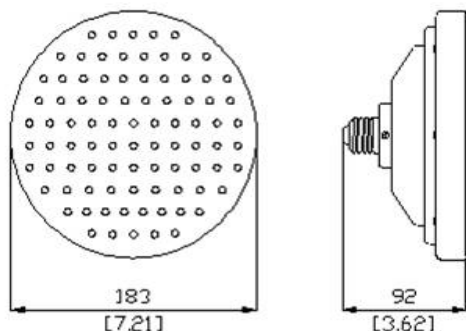

9 inch

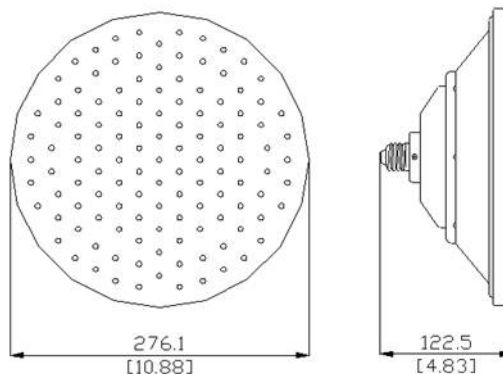

12 inch



Model Specifications and Ordering Options

Model Number and Color ¹	Wattage Drawn	Voltage
9 inch		
T9W-C-2100 	8.5	80-135Vac
T9E-C-2100 	7	80-135Vac
12 inch		
T12W-C-2100 	11	80-135Vac
T12E-C-2100 	8.5	80-135Vac

¹All models are "Type 2" Full Ball.

Standard Conformance



- FCC Compliant for Electrical Noise
- MIL-STD-810F Moisture Resistant
- MIL-STD-883 Mechanical Vibration
- NEMA TS2 Transient Voltage Protection over 2000V

LEOTEK USA
 1330 Memorex Drive
 Santa Clara, CA 95050
 Toll Free: (888) 806-1188
 Fax: (408) 980-0538

LEOTEK TAIWAN
 No. 50 Lung-Yuan 7th Road
 Lung-Tan, Tao-Yuan Hsien 325
 Taiwan
 Telephone: 886-3-4995939
 Fax: 886-3-4995930

www.leotek.com
www.liteon.com

